

EC Motor

Application

The EVO/™ECM-4Spd allows ~24V thermostats and controls to select one of four adjustable flow indexes¹ for a PWM controlled EC Motor. (See EVO/10Y-4Spd for 0 to +10V output).

The control has four taps to select the desired flow index. An adjustment associated with each tap sets the flow index to the desired value. The adjustment range is from Off to 100% of the programmed control range. A fifth adjustment sets the flow index when no tap is selected.

The EVO/™ECM-4Spd changes the flow index at a 1% per second rate. This ramping feature reduces occupant awareness of changes in diffuser airflow.

Features

- * Isolated Taps
- * Taps Off Setting
- * Fast or Gradual Speed Change
- * Pilot Pulse Enable/Disable

Specifications

Power	~24V NEC Class 2 ^{USA} ~24V ± 20% 50/60 Hz 2 W, 4 VA + 1VA/Motor
TAPS	~24V ± 20% 50/60 Hz 1k8 Ω load
Outputs	Go & VSpd +22 V @ 20 mA
<i>Vspd Supports Pilot Pulse (Autoswitch) Function</i>	
Therm. Stability	>0.01%/°F
Operating Environment	0°F to 130 °F (-18°C to 55°C) 10-80% rh
Connections	¼" Tabs

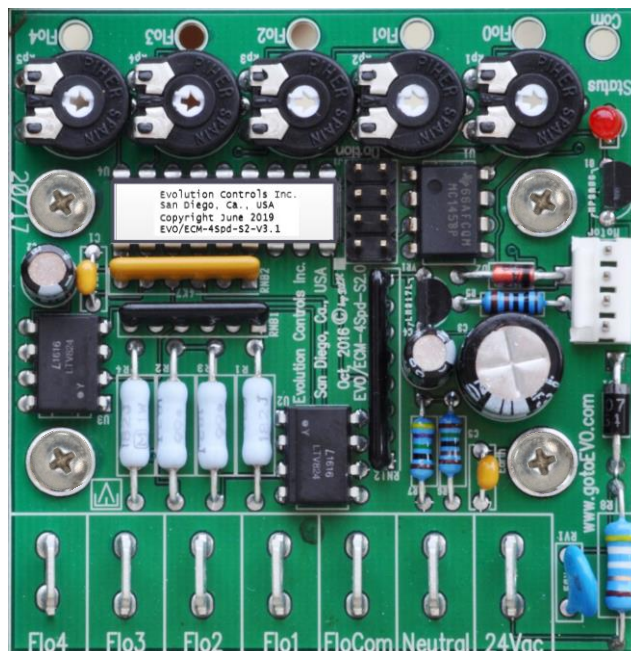

EVO/™ECM-4Spd

Ordering

EVO/™ECM-4Spd	OEM version
EVO/™ECM-4Spd-MP	Add Mounting Plate
EVO/™ECM-CBL-??	Control cable. ?? = length in ft.
EVO/™ECM-PBL-??	Power Cable. ?? = Length in ft.

Adjustment

Set each flow index by measuring the voltage between Com and the target flow point (Flo?). Set the target flow adjustment to the voltage associated with the desired flow index on the Voltage vs. Flow Index Chart.

When an adjustment is turned, ramping is temporarily disabled to allow dynamic adjustment of the flow index.

¹ Flow index = %PWM except at the end points

Voltage vs. Flow Index Chart

Direct Reading

0%	0	Flow	+V	Flow	+V	Flow	+V	Flow	+V	Flow	+V	Flow	+V	Flow	+V	Flow	+V	Flow	+V
1%	0.15	11%	0.64	21%	1.13	31%	1.62	41%	2.11	51%	2.60	61%	3.09	71%	3.58	81%	4.07	91%	4.56
2%	0.20	12%	0.69	22%	1.18	32%	1.67	42%	2.16	52%	2.65	62%	3.14	72%	3.63	82%	4.12	92%	4.61
3%	0.25	13%	0.74	23%	1.23	33%	1.72	43%	2.21	53%	2.70	63%	3.19	73%	3.68	83%	4.17	93%	4.66
4%	0.29	14%	0.78	24%	1.27	34%	1.76	44%	2.25	54%	2.75	64%	3.24	74%	3.73	84%	4.22	94%	4.71
5%	0.34	15%	0.83	25%	1.32	35%	1.81	45%	2.30	55%	2.79	65%	3.28	75%	3.77	85%	4.26	95%	4.75
6%	0.39	16%	0.88	26%	1.37	36%	1.86	46%	2.35	56%	2.84	66%	3.33	76%	3.82	86%	4.31	96%	4.80
7%	0.44	17%	0.93	27%	1.42	37%	1.91	47%	2.40	57%	2.89	67%	3.38	77%	3.87	87%	4.36	97%	4.85
8%	0.49	18%	0.98	28%	1.47	38%	1.96	48%	2.45	58%	2.94	68%	3.43	78%	3.92	88%	4.41	98%	4.90
9%	0.54	19%	1.03	29%	1.52	39%	2.01	49%	2.50	59%	2.99	69%	3.48	79%	3.97	89%	4.46	99%	4.95
10%	0.59	20%	1.08	30%	1.57	40%	2.06	50%	2.55	60%	3.04	70%	3.53	80%	4.02	90%	4.51	100%	5.00

Mounting

Beginning with firmware version 3.0, equipment manufacturers can pre-configure the flow index for each call in EVO™ECM-4Spd without using the local adjustment. Equipment manufacturers can enable or disable the local Adjustment. When the local adjustment is disabled, the flow indexes cannot be changed. When the local adjustment is enabled, the corresponding adjustor can be used to make manual flow adjustment for the selected call.

Mount the control inside a metal control cabinet or enclosure. Fasten the control mounting posts to an earthed metal surface. Use #8 flat or oval head screws through the four metallic mounting posts. The countersink taper forces a good earth connection between the mounting post and the PC board. Mounting posts are 3/32"/2.38mm ID. Adjustment shafts are 0.20"/5mm dia.



Mount the control with clearance for the ~24V power wires and control cable connector. Mount the control so the status lamp is visible. Make sure there is access to the test points and the flow adjustments.

Dimensions

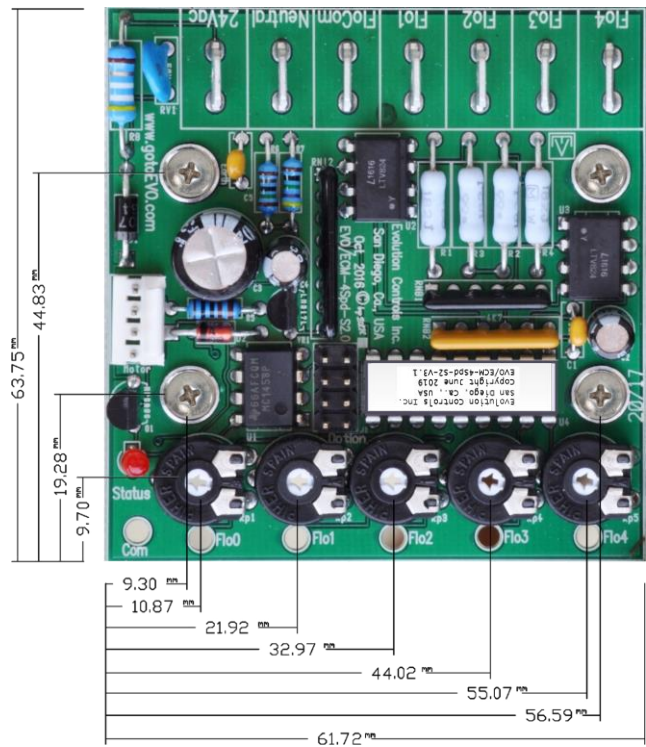
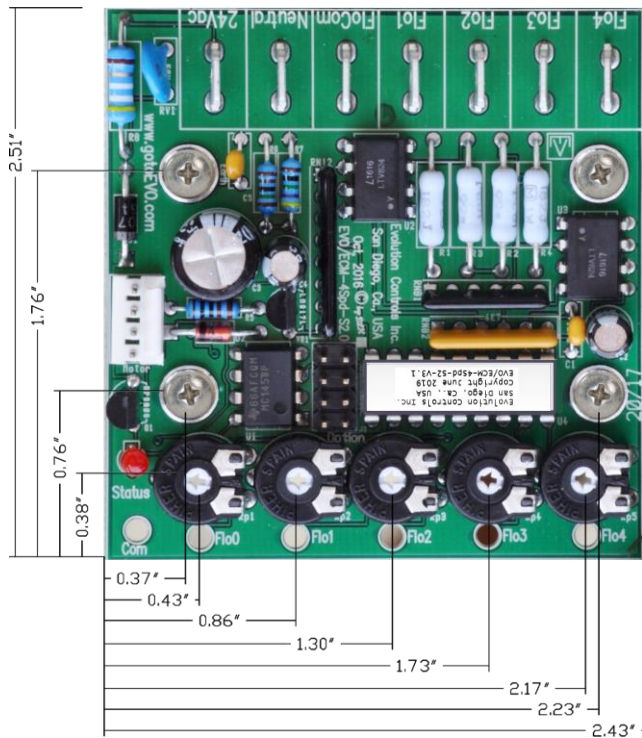

Options

Ramp Disable Insert jumper to disable the 1% PWM/second ramp rate (no delay).

Pilot Enable Insert jumper so the PWM never goes below 0.4% or above 99.6%. Some profiles allow the motor to run in an alternate mode when there is no pulse on the PWM input.

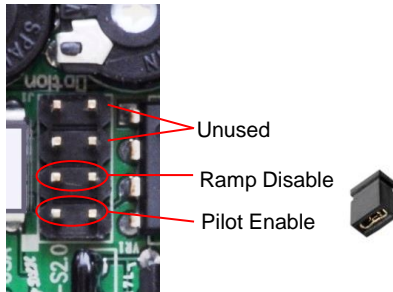

Wiring

Power the EVO/ECM-4Spd controller with a ~24V NEC UL 1310 Class 2 ^{USA} power source. Observe all code requirements and follow all safety practices regarding low voltage power supplies and circuits to insure a safe, reliable installation.

Earth one side of the power source. Connect the neutral connection to the earthed side of the ~24V Class 2 power source.

Some applications may require an isolated power supply or alternative earthing scheme. Follow code requirements and observe all safety practices concerning unearthed low voltage circuits.

Connect the ~24V connection to the hot side of the ~24V Class 2 power source. You may interrupt this connection as a means to stop the EC Motor. This is especially useful if you plan to set a flow with no taps active (Flo0). Many automation controllers will power the control directly from an on/off output.

Tap isolation allows the taps to be powered from a device using a different ~24V power source than the ~24V used to power the EVO/™ECM-4Spd.

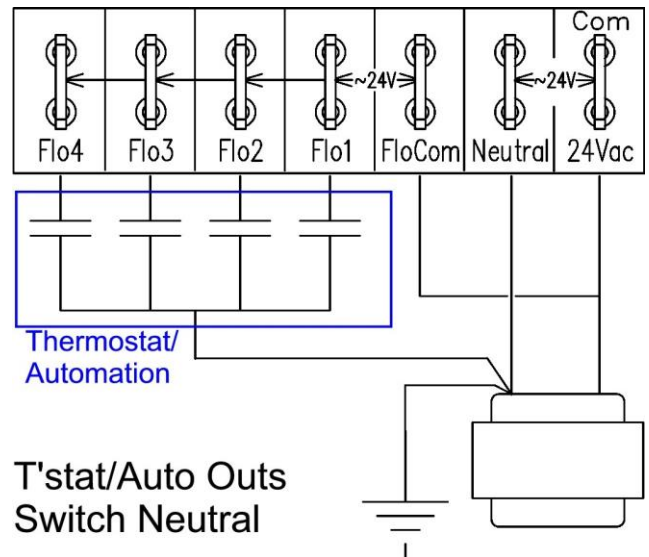
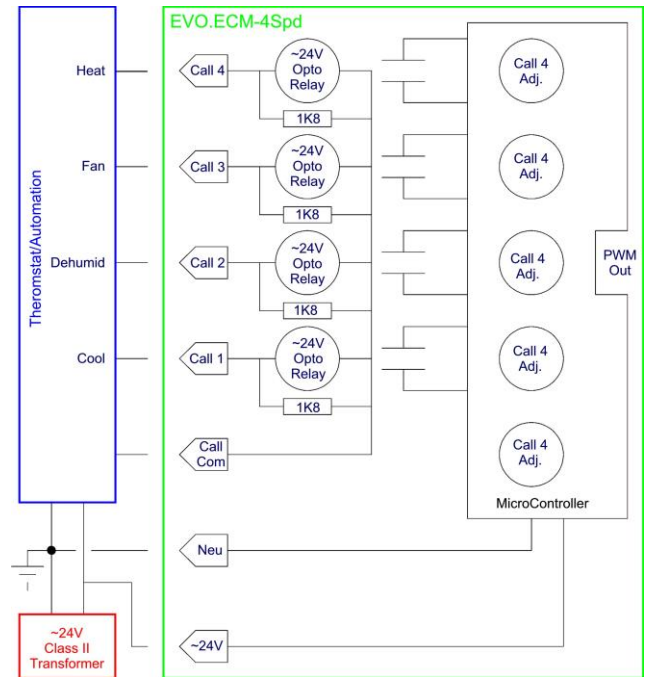

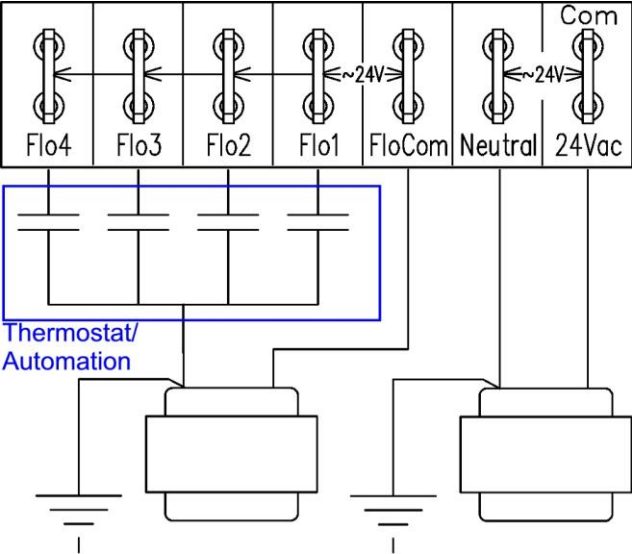

Different ~24V Supplies

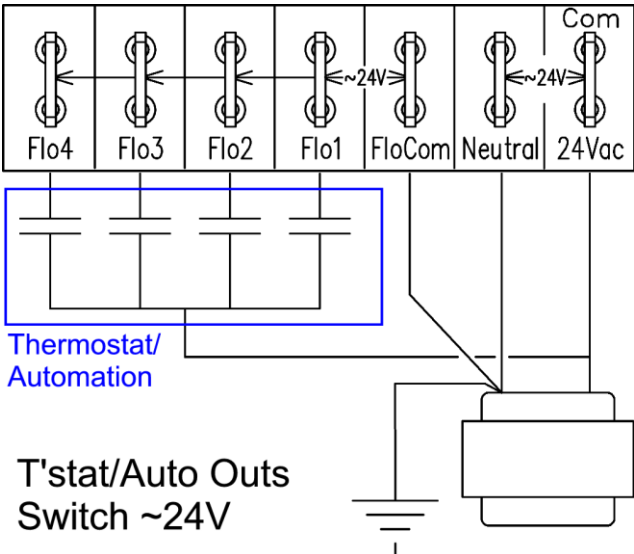

T'stat/Auto Outs Switch ~24V

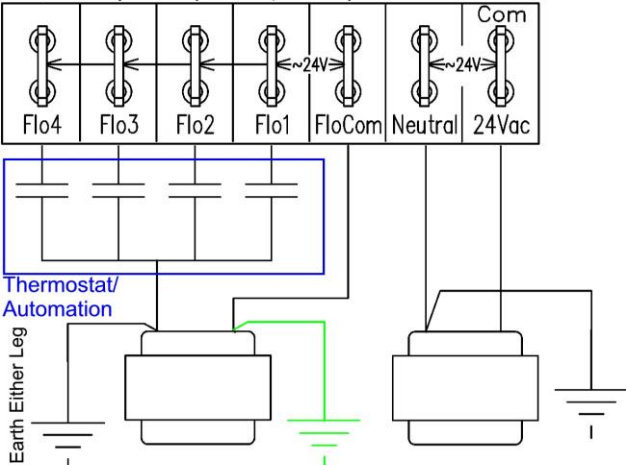
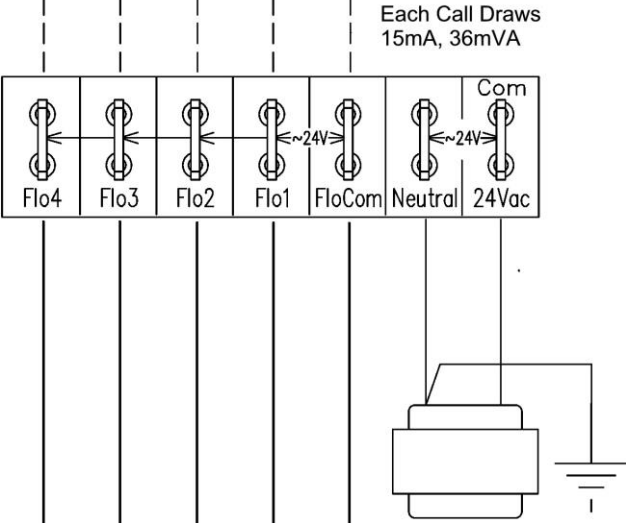

Multiple Machines Share Same T'stat/Automation

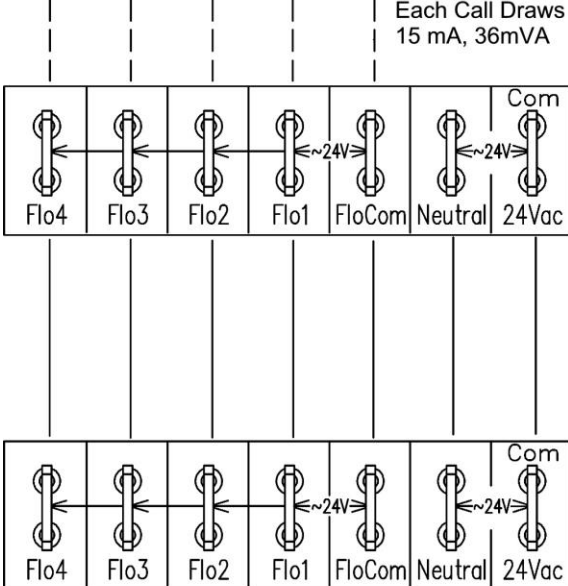

Multiple 4Spds In Same Machine (EVO/ECM-4Spds or EVO/10Y-4Spds)

EVO™ECM-4Spd-MP

With the mounting plate option "M", the 4Spd mounts to a standard 2 gang electrical box or equivalent cutout in a machine's sheet metal.

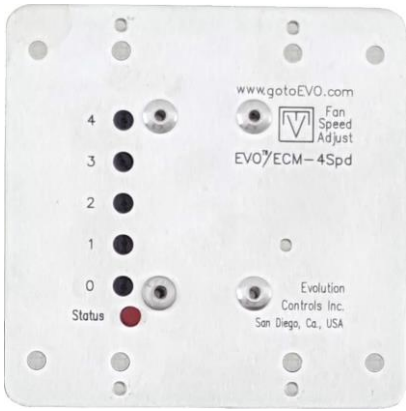

Place a label to the right of the adjusters to indicate the function of each.

Label: Heating, Cooling, High, Med, Low, Stg 1, Stg 2, etc.
See picture example, bottom left.

The voltage to %PWM relationship reverses when adjusted from the back side, so the reverse reading chart below must be used instead of the direct reading chart.

Reverse Reading

0%	5.00	Flow	+V	Flow	+V	Flow	+V	Flow	+V	Flow	+V	Flow	+V	Flow	+V	Flow	+V	Flow	+V
1%	4.85	11%	4.36	21%	3.87	31%	3.38	41%	2.89	51%	2.40	61%	1.91	71%	1.42	81%	0.93	91%	0.44
2%	4.80	12%	4.31	22%	3.82	32%	3.33	42%	2.84	52%	2.35	62%	1.86	72%	1.37	82%	0.88	92%	0.39
3%	4.75	13%	4.26	23%	3.77	33%	3.28	43%	2.79	53%	2.30	63%	1.81	73%	1.32	83%	0.83	93%	0.34
4%	4.71	14%	4.22	24%	3.73	34%	3.24	44%	2.75	54%	2.25	64%	1.76	74%	1.27	84%	0.78	94%	0.29
5%	4.66	15%	4.17	25%	3.68	35%	3.19	45%	2.70	55%	2.21	65%	1.72	75%	1.23	85%	0.74	95%	0.25
6%	4.61	16%	4.12	26%	3.63	36%	3.14	46%	2.65	56%	2.16	66%	1.67	76%	1.18	86%	0.69	96%	0.20
7%	4.56	17%	4.07	27%	3.58	37%	3.09	47%	2.60	57%	2.11	67%	1.62	77%	1.13	87%	0.64	97%	0.15
8%	4.51	18%	4.02	28%	3.53	38%	3.04	48%	2.55	58%	2.06	68%	1.57	78%	1.08	88%	0.59	98%	0.10
9%	4.46	19%	3.97	29%	3.48	39%	2.99	49%	2.50	59%	2.01	69%	1.52	79%	1.03	89%	0.54	99%	0.05
10%	4.41	20%	3.92	30%	3.43	40%	2.94	50%	2.45	60%	1.96	70%	1.47	80%	0.98	90%	0.49	100%	0.00

Place a decorative plate or protective cover over the 4Spd where required. Use self-threading screws, or a hand tap to thread the 4 holes that fasten the cover to the 4Spd plate.

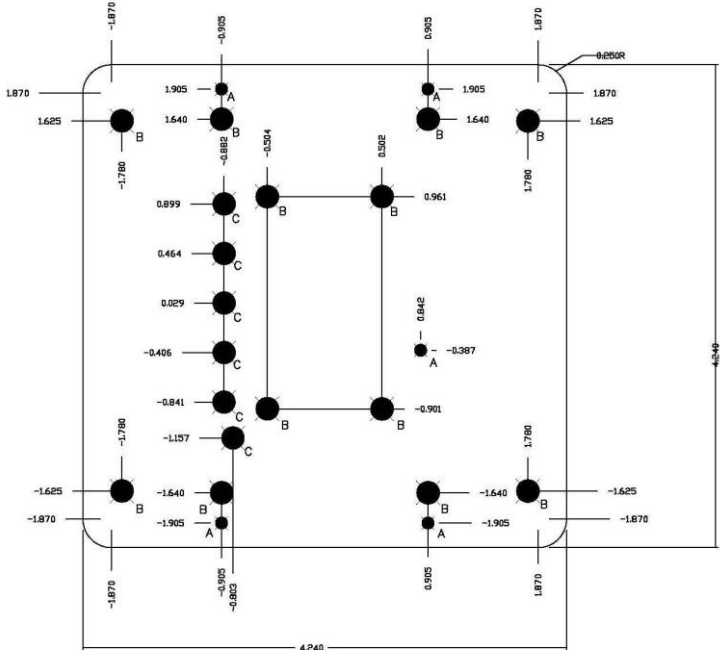

a. All ordinates from plate center.
b. All DIM. in inches
c. Tolerance:
Hole Diameter = +/- 0.003"
Hole to Hole = +/- 0.005"
Edge to Hole = 0.010"
Edge to Edge = 0.010"
Corner Radius = 0.010"
d. Material:
16 Ga. (0.0508") 5052
H32 Aluminum Sheet.

HOLE SIZE	QTY	SYM
0.109	5	A
0.200	12	B
0.219	6	C

Evolution Controls Inc.